

AMTRON®

Professional+ PnC 22

For charging electric vehicles in semi-public and public areas



MENNEKES
Elektrotechnik GmbH & Co. KG

Aloys-Mennekes-Straße 1
57399 Kirchhundem
GERMANY

www.chargeupyourday.com

Equipment features

General

- Mode 3 charging (IEC 61851-1)
- Plugs and sockets according to IEC 62196-2
- Communication with the vehicle according to ISO 15118
- Maximum charging power: 22 kW
- Connection: 1-phase / 3-phase
- Max. charging power configurable by qualified electrician
- Calibrated energy meter, readable from outside (MID-compliant for three-phase supply network connection only)
- Status information via LED information panel
- Unlocking function in case of power failure
- Integrated cable hanger
- Enclosure made of AMELAN
- Multi-function button
 - Switch the residual current device and the circuit breaker back on again from the outside
 - Check the residual current device for damage from the outside

Authorisation options

- Autostart (without authorisation)
- RFID (ISO / IEC 14443 A)
 - Compatible with MIFARE classic and MIFARE DESFire
- Via a backend system
- Plug and Charge
 - According to ISO 15118
 - Via vehicle ID (Autocharge)

Networking options

- Connecting to a network via LAN / Ethernet (RJ45)
- Networking multiple products via LAN / Ethernet (RJ45)

Options for connecting to a backend system

- Via the integrated wireless modem (2G (GSM) / 3G (UMTS) / 4G (LTE))
 - Micro-SIM card required
- Backend connection of up to 50 charging points via a SIM card
- Support for OCPP 1.5s, OCPP 1.6s and OCPP 1.6j communication protocols

Options for local load management

- Reduction of the charging current via an external control signal (downgrade) of the upstream, external energy meter type Siemens PAC2200
- Static load management
- Dynamic load management for up to 100 charging points (phase exact)
- Local blackout protection by connecting an external Modbus TCP energy meter

Options for connecting to an external energy management system (EMS)

- Via Modbus TCP

- Dynamic control of the charging current via an OCPP system (smart charging)

Integrated protective devices

- Residual Current Device type A
- Circuit breaker
- DC residual current monitoring > 6 mA with tripping characteristics in accordance with IEC 62752
- Shunt release, in order to disconnect the charging point voltage in case of a fault (sticking load contactor) (welding detection)

Compatible meter for blackout protection

MENNEKES recommends using the following devices:

1. Siemens PAC 2200:

- Indirect measurement via a transducer (5 A):
 - 7KM2200-2EA30-1JA1 (with MID approval)
 - 7KM2200-2EA30-1EA1 (without MID approval)
- Direct measurement (up to 65 A):
 - 7KM2200-2EA40-1JA1 (with MID approval)
 - 7KM2200-2EA40-1EA1 (without MID approval)

2. Phoenix EEM-MB371-EIP 2907976

3. Kostal Smart Energy Meter 10507524

4. TQ Energy Manager EM 420-LLRR

Technical data

AMTRON® Professional+ PnC 22		1367402
Max. charging power Mode 3 [kW]	Charging point 1	22
Connection	Charging point 1	1-phase / 3-phase
Rated current I_{nA} [A]		32
Rated current of a Mode 3 I_{nC} charging point [A]		32
Rated voltage U_N [V] AC $\pm 10\%$		230 / 400
Rated frequency f_N [Hz]		50
Switching device load circuit (load contactor)		32A, 4p (100-250V 50/60Hz)
Max. back-up fuse [A]		According to rating plate / configuration
Rated insulation voltage U_i [V]		500
Rated impulse withstand voltage U_{imp} [kV]		4
Conditional rated short-circuit current I_{CC} [kA]		10
Rated diversity factor RDF		1
Types of system earthing		TN/TT
EMC classification		A+B
Protection class		II
IP rating		IP44
Overvoltage category		III
Mechanical impact protection		IK10
Contamination rating		3
Installation		open air, interior
Stationary / Mobile		fixed
Use (according to IEC 61439-7)		ACSEV
External design		wall mounting
Dimensions H x W x D [mm]		According to dimensional drawing
Weight [g]		8600
Standard		IEC 61851, IEC 61439-7

The specific standards according to which the product was tested can be found in the declaration of conformity for the product.

Technical data

Permissible ambient conditions

	Min.	Max.
Ambient temperature [°C]	-30	50
Average temperature over 24 hours period [°C]		35
Altitude [m above sea level]		2000
Relative humidity [%]		95

Protective devices

Personal protection (RC)	40 / 0,03A, 4p, type A
Load safety (LS)	C-32A, 3p+N, 10kA
Control fuse (LS)	B-6A, 2p, 10kA

Technical data

Supply line terminal strip

Number of terminals	5	
Line material	Copper	
	Min.	Max.
Clamping range - rigid [mm ²]	0.5	10
Clamping range - flexible [mm ²]	0.5	10
Clamping range with ferrule [mm ²]	0.5	10
Tightening torque [Nm]	1.5	1.8

Shunt release relay

Number of terminals	2	
Coil voltage [V]	-	
	Min.	Max.
Clamping range - rigid [mm ²]	-	6
Clamping range - flexible [mm ²]	-	4
Clamping range with ferrule [mm ²]	-	4
Tightening torque [Nm]	0.8	0.8

Dimensional drawing

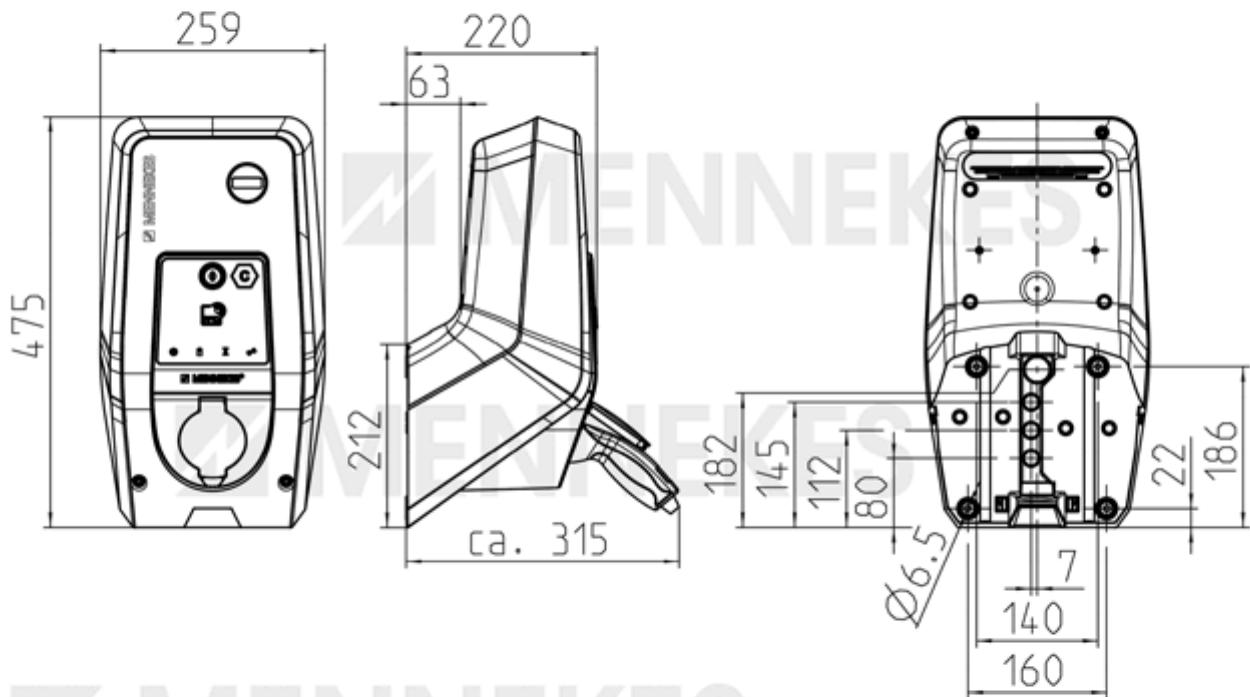

1 MB 682

Example

